

MULTITIMER

Multifunction Relay

IK 7817N/200, SK 7817N/200



- According to IEC/EN 61 812-1
 - 8 functions settable via rotational switch:
 - Delay on energisation (AV)
 - Fleeting on make (EW)
 - Delay pulse (IE)
 - Flasher, start with pulse (BI)
 - Delay on de-energisation (RV)
 - Pulse forming function (IF)
 - Fleeting on break (AW)
 - Delay on energisation and de-energisation (AV / RV)
 - 8 time ranges from 0.02 s ... 300 h selectable via rotational switches
 - Voltage range AC/DC 12 ... 240 V
 - With time interruption / time adding input
 - Adjustment aid for quick setting of long time values
 - Suitable for 2-wire proximity sensor control
 - 1 changeover contact
 - LED indicators for operation, contact position and time delay
 - Devices available in 2 enclosure versions:
 - IK 7817N: depth 59 mm, with terminals at the bottom for installation systems and industrial distribution systems according to DIN 43 880
 - SK 7817N: depth 98 mm, with terminals at the top for cabinets with mounting plate and cable duct
 - DIN rail or screw mounting
 - 17.5 mm width
- IK/SK 7817N/500: as IK/SK 7817N/200 but with
- 2 additional functions:
 - Cyclic timer, start with break (TP)
 - Fleeting on make and break (EW / AW)
 - second time setting t2 for functions
 - Cyclic timer, start with pulse (TI) or break (TP), based on the separate setting of pulse and break time the flasher function can be used as cyclic timer.
 - Fleeting on make and break (EW/AW)
 - Delay on energisation and de-energisation (AV / RV)
 - Delay pulse (IE): setting of pulse length
 - Connection facility for external potentiometer 10 kΩ

Circuit Diagrams

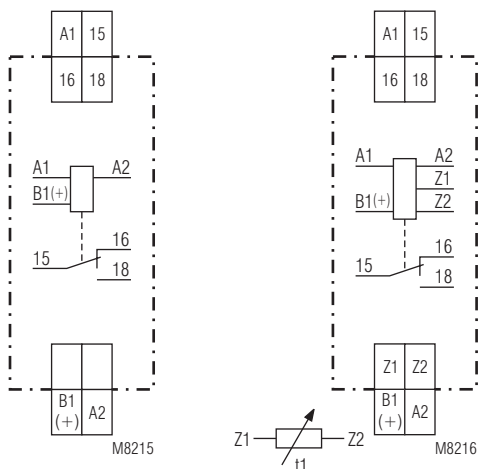

IK 7817N.81/200
SK 7817N.81/200

IK 7817N.81/500
SK 7817N.81/500

Approvals and Markings



Application

Time dependent controls for industrial and railway applications.

Indicators

| | |
|---------------------------------|--|
| green LED: | on, when voltage connected |
| yellow LED "R/t": | shows status of output relay and time delay: |
| - Continuously off: | output relay not active; no time delay |
| - Continuously on: | output relay active; no time delay |
| - Flashing (short on, long off) | output relay not active; time delay |
| - Flashing (long on, short off) | output relay active; time delay |

Notes

Control of A1-A2 with proximity sensors

The input can be controlled by DC 3 wire or AC/DC 2 wire proximity sensors. For operating voltage > 24 V and usage of sensors without built-in short circuit protection a protection resistor on A1 is recommended to reduce the inrush current. The dimension is as follows:

$$R_v \approx \text{operating voltage} / \text{max. switching current of sensor}$$

The series resistor must not be selected higher than necessary.

Max. values are:

| | | | | |
|----------------------------|-------|-------|-------|--------------|
| Operating voltage: | 48 V | 60 V | 110 V | 230 V |
| Series resistor R_v max: | 270 Ω | 390 Ω | 680 Ω | 1.8 kΩ (1 W) |

Connection Terminals

| Terminal designation | Signal designation |
|-------------------------------|---|
| A1 | L / + |
| A2 | N / - |
| B1(+) | Control input (different function depending on chosen timing function) control with reference to A2 |
| 15, 16, 18 | Changeover contact |
| Z1, Z2 (only at variant /500) | Input to connect a remote potentiometer for time setting t1 |

Function Diagram

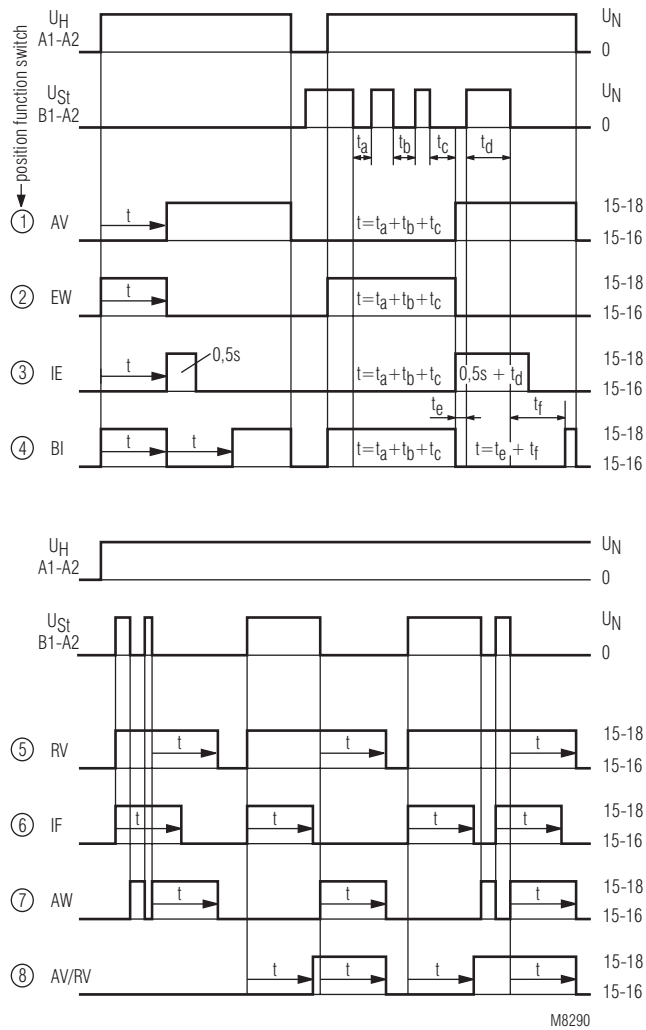

IK 7817N/200, SK 7817N/200

① ... ⑧ = position of function switch

- | | |
|----------------------------------|---|
| ① AV = Delay on energisation | ⑤ RV = Delay on de-energisation |
| ② EW = Fleeting on make | ⑥ IF = Pulse forming function |
| ③ IE = Delayed pulse | ⑦ AW = Fleeting on break |
| ④ BI = Flasher, start with pulse | ⑧ AV/RV = Delay on energisation and de-energisation |

Function Diagram

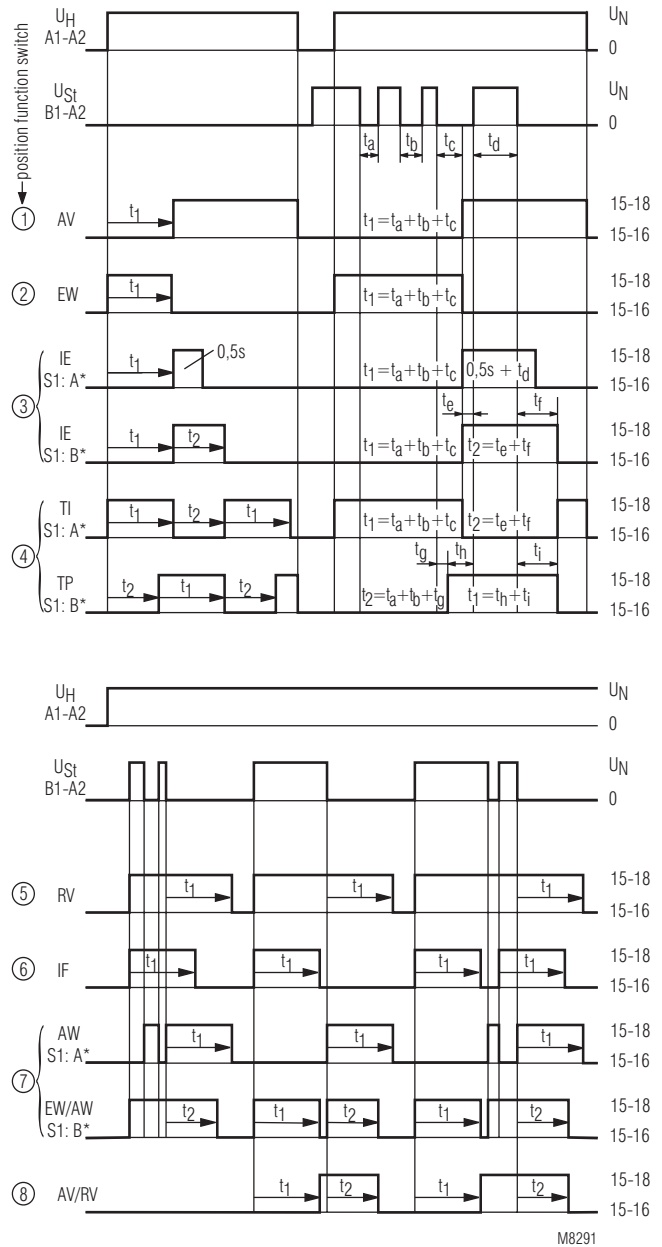

IK 7817N/500, SK 7817N/500

① ... ⑧ = position of function switch

- | | |
|---|---|
| ① AV = Delay on energisation | ⑤ RV = Delay on de-energisation |
| ② EW = Fleeting on make | ⑥ IF = Pulse forming function |
| ③ IE = Delay pulse | ⑦ AW = Fleeting on break |
| S1 in position A: t1:adjustable, t2 = 0.5 s fixed | |
| S1 in position B: t1 and t2 adjustable | |
| ④ TI = Cyclic timer, start with pulse | ⑧ AV/RV = Delay on energisation and de-energisation |
| S1 in position A | |
| S1 in position B | |
| TP = Cyclic timer, start with break | |
| S1 in position B | |

Setting

If the function switch is altered during operation, the new setting is valid immediately (like a restart of the relay).

A new adjustment of the time or time range is also immediately valid.

Please note, that a change of function, time range or time setting during elapse of time can lead to unintended switching of the output contacts.

Adjustment assistance

The flashing period of the yellow LED is $1\text{ s} \pm 4\%$ and can be used to adjust the time. Especially on the lower end of scale and for long times it is suitable as the multiplication factors between the different time ranges are exact without tolerance.

Example:

The required time is 40 min. It has to be adjusted within range 3 ... 300 min. The time check takes too long as several timing cycles would be necessary for a precise value. For faster adjustment the setting is made to 0.03 ... 3 min. On this range the potentiometer should be set to 0.4 min (= 24 sec.). With the right potentiometer setting the LED must show 24 flashing cycles. After that the time range is switched over to 3 ... 300 min. and the setting is complete.

Time interruption / time adding

With the functions AV, EW, IE and BI the time delay can be interrupted by controlling input B1 (+) with control voltage. Removing the control signal will continue the timing cycle (time addition).

Control input B1

The functions RV, IF, AW, AV / RV have to be controlled via input B1 (+) with voltage against A2. The control signal could be the same as the auxiliary/control voltage of A1 or any other voltage between 12 and 240 V AC or DC. Operating a parallel load between B1 and A2 is also possible.

If with function IF the inputs A1 and B1 are controlled simultaneously a pulse with the adjusted length is started.

With the variant IK/SK 7817N/500 the output pulse can be disabled by setting the slide switch in position "B".

Remote potentiometer

The setting of t1 on variant IK/SK 7817N/500 can also be made by a remote potentiometer of 10 kOhms. The connection is made via Z1-Z2. When connecting a remote potentiometer the rotational switch for t1 has to be set to min. If no remote potentiometer is required the terminals Z1-Z2 have to be linked.

The wires to the remote potentiometer should be installed separately from the lines with mains voltage. If this is not possible, a screened cable is recommended where the shield is connected to Z1.

To terminals Z1 and Z2 no external voltage must be connected, as the unit might be damaged.

Terminals Z1-Z2 do not have a galvanic separation to terminals A1 -A2!

Additional function

With the variant IK/SK 7817N/500 additional features can be selected for the functions position 3, 4 and 7 using the slide switch S1 on the relay front in position "B". At the same time a second time setting t2 is available on the lower rotational switch for the functions 3, 4, 7 and 8 (see function Diagram). The time range is the same as for t1.

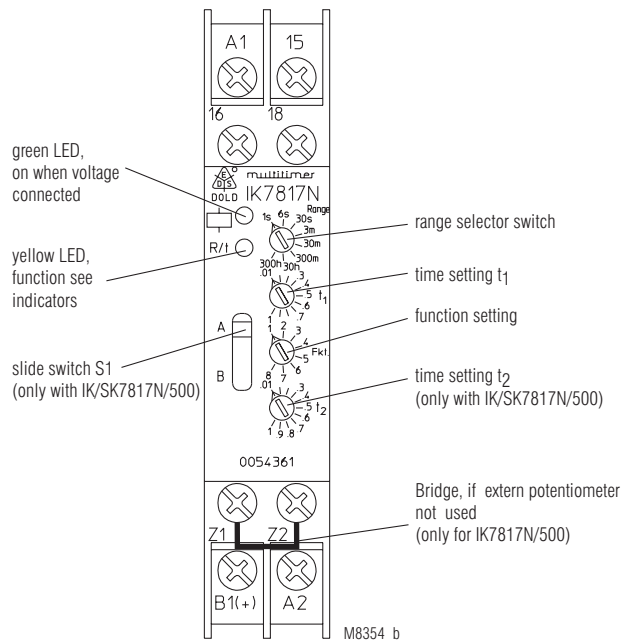
**Attention**

If no remote potentiometer at IK/SK 7817N/500 is required the terminals Z1-Z2 have to be linked.

Technical Data

Time circuit

| | |
|-----------------------------|--|
| Time ranges: | 8 time ranges in one unit, settable via rotational switch |
| | 0.02 ... 1 s 0.3 ... 30 min |
| | 0.06 ... 6 s 3 ... 300 min |
| | 0.3 ... 30 s 0.3 ... 30 h |
| | 0.03 ... 3 min 3 ... 300 h |
| Time setting t1, t2: | continuous, 1:100 on relative scale (t2 only at IK/SK 7817N/500) |

| | |
|-------------------------|--|
| Recovery time: | |
| at DC 24 V: | approx. 15 ms |
| at DC 240 V: | approx. 50 ms |
| at AC 230 V: | approx. 80 ms |
| Repeat accuracy: | ± 0.5 % of selected end of scale value + 20 ms |

| | |
|---|---|
| Voltage and temperature influence: | < 1 % with the complete operating range |
|---|---|

Input

| | |
|---|--|
| Nominal voltage U_N: | AC/DC 12 ... 240 V |
| Voltage range: | 0.8 ... 1.1 U _N |
| Release voltage (A1/A2) | |
| AC 50 Hz: | approx. 7.5 V |
| DC: | approx. 7 V |
| Max. permitted residual current with 2-wire proximity sensor control (A1-A2) | |
| up to AC/DC 150 V: | AC resp. DC 5 mA |
| up to AC/DC 264 V: | AC resp. DC 3 mA |
| Control current B1: | input resistance approx. 220 kΩ in series with diode |

| | |
|---|-------------------------------|
| Min. on/off time of control input B1(+): | |
| AC 50 Hz: | approx. 15 ms / approx. 60 ms |
| DC: | approx. 5 ms / approx. 60 ms |

| | |
|--------------------------------|-------------|
| Release voltage (B1/A2) | |
| AC 50 Hz: | approx. 5 V |
| DC: | approx. 4 V |

| | |
|----------------------------------|----------------|
| Nominal power consumption | |
| AC 12 V: | approx. 1.5 VA |
| AC 24 V: | approx. 2 VA |
| AC 240 V: | approx. 3 VA |
| DC 12 V: | approx. 1 W |
| DC 24 V: | approx. 1 W |
| DC 240 V: | approx. 1 W |
| Nominal frequency: | 45 ... 400 Hz |

Output

| | |
|--|---|
| Contacts: | 1 changeover contact |
| Contact material: | AgNi |
| Measured nominal voltage: | AC 250 V |
| Thermal current I_{th}: | max. 4 A (see see quadratic total current limit curve) |

| | |
|---------------------------|-------------------------------------|
| Switching capacity | |
| to AC 15 | |
| NO contact: | 3 A / AC 230 V IEC/EN 60 947-5-1 |
| NC contact: | 1 A / AC 230 V IEC/EN 60 947-5-1 |
| to DC 13 at 0.1 Hz: | 1 A / DC 24 V IEC/EN 60 947-5-1 |

| | |
|----------------------------|--|
| Electrical life | |
| to AC 15 at 1 A, AC 230 V: | 1.5 x 10 ⁵ switch. cycles IEC/EN 60 947-5-1 |

| | |
|--|-----------------------------|
| Permissible switching frequency | 36 000 switching cycles / h |
|--|-----------------------------|

| | |
|---|---|
| Short circuit strength max. fuse rating: | 4 A gL IEC/EN 60 947-5-1 |
| Mechanical life: | ≥ 30 x 10 ⁶ switching cycles |

Technical Data

General Data

| | |
|-------------------------------|---|
| Operating mode: | Continuous operation |
| Temperature range: | |
| Operation: | - 40 ... + 60 °C (higher temperature with limitations see quadratic total current limit curve) |
| | - 40 ... + 70 °C |
| | 93 % at 40 °C |
| Storage: | |
| Relative air humidity: | < 2.000 m |
| Altitude: | |

| | |
|---|--|
| Clearance and creepage distances | |
| rated impulse voltage / pollution degree: | 4 kV / 2 (basis insulation) IEC 60 664-1 III |
| Overvoltage category: | |
| Insulation test voltage, type test: | 2.5 kV; 1 min |

| | |
|--|-----------------------------------|
| EMC | |
| Electrostatic discharge: | 8 kV (air) IEC/EN 61 000-4-2 |
| HF-irradiation | |
| 80 MHz ... 1 GHz: | 20 V / m IEC/EN 61 000-4-3 |
| 1 GHz ... 2.7 GHz: | 10 V / m IEC/EN 61 000-4-3 |
| Fast transients: | 4 kV IEC/EN 61 000-4-4 |
| Surge voltages between wires for power supply: | 2 kV IEC/EN 61 000-4-5 |
| between wire and ground: | 4 kV IEC/EN 61 000-4-5 |
| HF-wire guided: | 10 V IEC/EN 61 000-4-6 |
| Interference suppression: | Limit value class B EN 55011 |

| | |
|-----------------------------|--|
| Degree of protection | |
| Housing: | IP 40 IEC/EN 60 529 |
| Terminals: | IP 20 IEC/EN 60 529 |
| Housing: | Thermoplastic with V0 behaviour according to UL subject 94 |

| | |
|------------------------------|---|
| Vibration resistance: | Amplitude 0.35 mm, frequency 10 ... 55 Hz, IEC/EN 60 068-2-6 40 / 060 / 04 IEC/EN 60 068-1 |
|------------------------------|---|

| | |
|----------------------------|-----------|
| Climate resistance: | EN 50 005 |
|----------------------------|-----------|

| | |
|------------------------------|--|
| Terminal designation: | DIN 46 228/-1/-2/-3/-4 |
| Wire connection: | 2 x 2,5 mm ² solid or 2 x 1,5 mm ² stranded wire with sleeve |
| Cross section: | 10 mm |

| | |
|--------------------------|--|
| Stripping length: | 10 mm |
| Wire fixing: | Flat terminals with self-lifting clamping piece IEC/EN 60 999-1 |

| | |
|-----------------------|--|
| Fixing torque: | 0.8 Nm |
| Mounting: | DIN rail mounting (IEC/EN 60715) or screw mounting M4, 90 mm hole pattern, with additional clip available as accessory |

| | |
|----------------|--------------|
| Weight: | |
| IK 7817N/200: | approx. 65 g |
| SK 7817N/200: | approx. 84 g |

Dimensions

| | |
|--------------------------------|-------------------|
| Width x height x depth: | |
| IK 7817N/200: | 17.5 x 90 x 59 mm |
| SK 7817N/200: | 17.5 x 90 x 98 mm |

Classification to DIN EN 50155

| | |
|--|--|
| Vibration and shock resistance: | Category 1, Class B IEC/EN 61 373 |
| Ambient temperature: | T1, T2 compliant T3 and TX with operational limitations |

| | |
|---------------------------------------|----|
| Protective coating of the PCB: | No |
|---------------------------------------|----|

Standard Type

IK 7817N.81/200 AC/DC 12 ... 240 V
 Article number: 0054359
 • Output: 1 changeover contact
 • Nominal voltage U_N : AC/DC 12 ... 240 V
 • Time ranges: from 0.02 s ... 300 h
 • Width: 17.5 mm

SK 7817N.81/200 AC/DC 12 ... 240 V
 Article number: 0058364
 • Output: 1 changeover contact
 • Nominal voltage U_N : AC/DC 12 ... 240 V
 • Time ranges: from 0.02 s ... 300 h
 • Width: 17.5 mm

Variant

IK/SK 7817N.81/500: With 2 additional functions selectable via slide switch S1:
 - Cyclic timer, start with break (TP)
 - Fleeting on make and break (EW/AW)
 second time setting t_2 , connection facility for remote potentiometer 10 k Ω (t_1)

Ordering example for variant

IK 7817N .81 / _ _ _ AC/DC 12 ... 240 V

Nominal voltage
 Variant
 Contacts
 Type

Characteristics

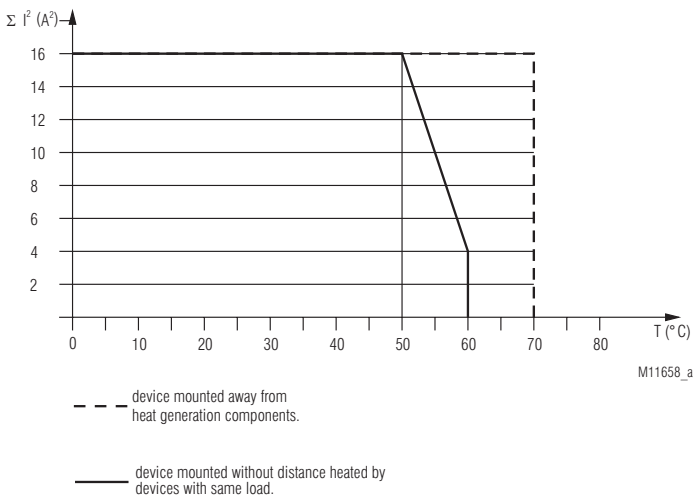

Accessories

AD 3:

External potentiometer 10 k Ω
 Article number: 0028962

The external potentiometer is used for remote setting of the time delay. The internal potentiometer of the timer must be set to min. time delay.

Degree of protection front side: IP 60

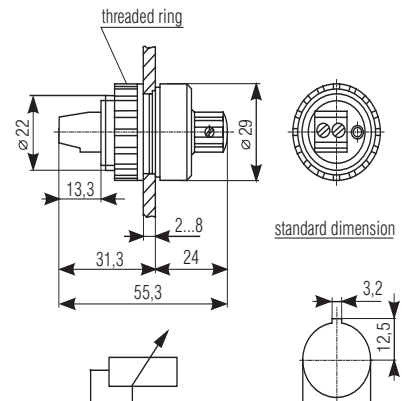

ET 4086-0-2:

Additional clip for screw mounting
 Article number: 0046578

Connection Examples

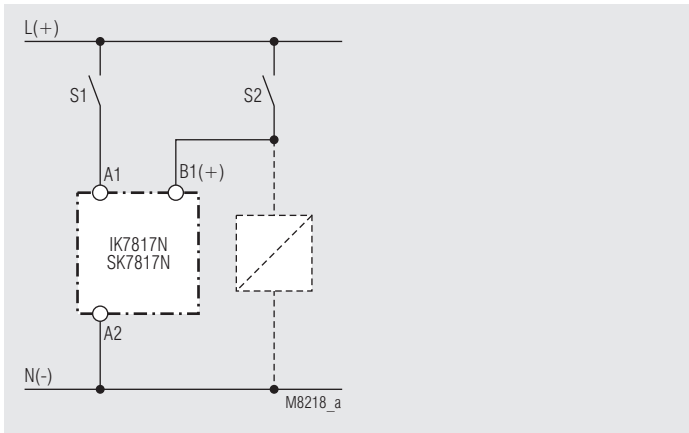
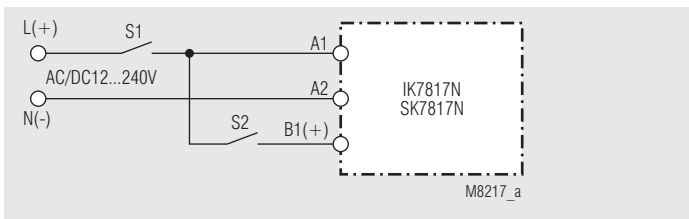

Control with parallel connected load

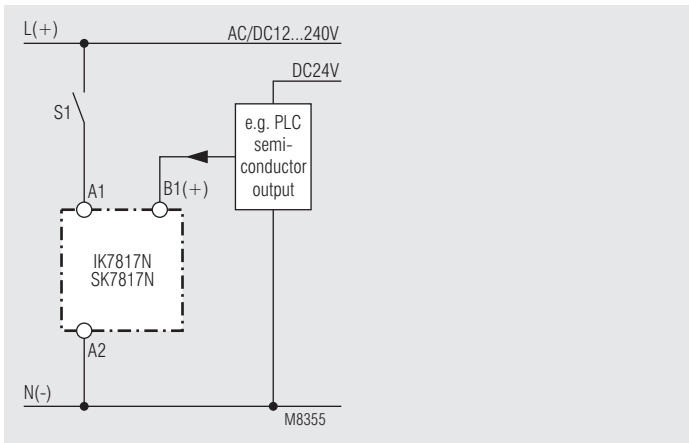

Connection with 2 different control voltages.