

MINITIMER Timer, On delayed MK 9906N



Your Advantages

- 8 time ranges in one unit
- Simplified storage
- High accuracy
- Quick setting of long time values

Features

- According to IEC/EN 61 812-1
- 8 time ranges from 0.05 s to 300 h selectable via rotational switches
- Voltage range AC/DC 12 ... 240 V
- Adjustment aid for quick setting of long time values
- Suitable for 2-wire proximity sensor control
- 2 changeover contacts, one programmable as instantaneous contact
- LED indicators for operation, contact position and time delay
- Wire connection: also 2 x 1.5 mm² stranded ferruled, or 2 x 2.5 mm² solid DIN 46 228-1/-2/-3/-4
- As option connection of a remote potentiometer
- As option with time interruption / time adding input
- As option with pluggable terminal blocks for easy exchange of devices
 - with screw terminals
 - or with cage clamp terminals
- 22.5 mm width

Function Diagram

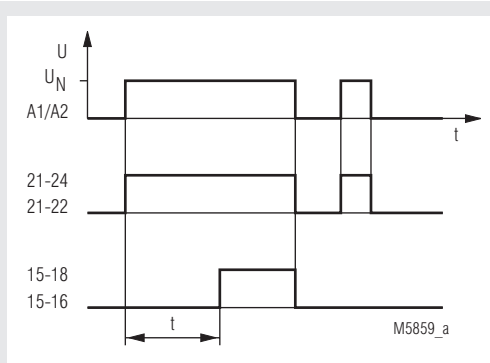

Approvals and Markings



* see variants

Application

Time-dependent controllers

Circuit Diagrams

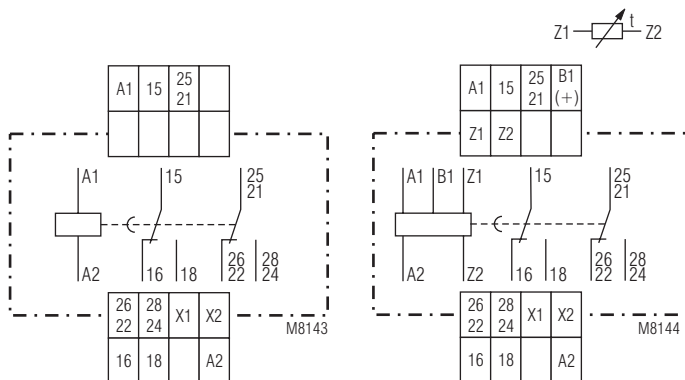

MK 9906N.82

MK 9906N.82/500

Indications

- green LED: on when voltage connected
 yellow LED "R/t": shows status of output relay and time delay:
- Flashing (long on, short off) output relay not active; time delay
 - Continuously on: output relay active after time delay

Notes

Control of A1-A2 with proximity sensors

The input can be controlled by DC 3 wire or AC/DC 2 wire proximity sensors. For operating voltage > 24 V and usage of sensors without built-in short circuit protection a protection resistor on A1 is recommended to reduce the inrush current. The dimension is as follows:

$$R_v \approx \text{operating voltage} / \text{max. switching current of sensor}$$

The series resistor must not be selected higher than necessary.

Max. values are:

Operating voltage:	48 V	60 V	110 V	230 V
Series resistor R_v max:	270 Ω	390 Ω	680 Ω	1.8 k Ω (1 W)

Instantaneous contact

By external wire links the output function of the device can be altered from 2 delayed contacts to 1 delayed **and** 1 instantaneous contact. The instantaneous contact switches when the operating voltage is connected. To terminals X1 and X2 no other voltage potentials must be connected, as the unit might be damaged.

Notes

Adjustment assistance

The flashing period of the yellow LED is $1\text{ s} \pm 4\%$ and can be used to adjust the time. Especially on the lower end of scale and for long times it is suitable as the multiplication factors between the different time ranges are exact without tolerance.

Example:

The required time is 40 min. It has to be adjusted within the range 3 ... 300 min. The time check takes too long as several timing cycles would be necessary for a precise value.

For faster adjustment the setting is made to 0.03 ... 3 min. On this range the potentiometer should be set to 0.4 min (= 24 sec). With the right potentiometer setting the LED must show 24 flashing cycles. After that the time range is switched over to 3 ... 300 min and the setting is complete.

Time interruption / Time adding

With the model MK 9906N.82/500 the timing cycle can be interrupted by controlling input B1 (+) with control voltage. Removing the control signal will continue the timing cycle (time addition). When time is interrupted the yellow LED goes off.

Control input B1

The control input B1 (+) has to be supplied with voltage against A2. The control signal must be the same as the auxiliary/control voltage of A1 or any other voltage between 12 and 240 V AC or DC. Operating a parallel load between B1 and A2 is also possible, which allows cost saving circuits.

Remote potentiometers

With the variant MK 9906N.82/500 the time setting can also be made via remote potentiometer of 10 kOhms. It is connected to the terminals Z1-Z2. The corresponding potentiometer on the relay has to be set to min. If no remote potentiometer is required the terminals Z1-Z2 have to be linked.

The wires to the remote potentiometers should be installed separately from the lines with mains voltage. If this is not possible, a screened cable is recommended where the shield is connected to Z2.

To terminals Z1 and Z2 no external voltage must be connected, as the unit might be damaged.

Setting

green LED
on when voltage
connected

yellow LED "R/t"
shows state of contacts
and timing
(see also indicators)

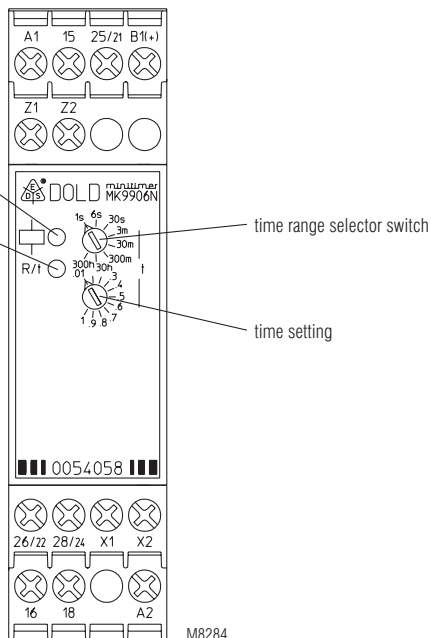

Technical Data

Time circuit

Time ranges:

8 time ranges settable via rotational switch:
 0.05 ... 1 s 0.3 ... 30 min
 0.06 ... 6 s 3 ... 300 min
 0.3 ... 30 s 0.3 ... 30 h
 0.03 ... 3 min 3 ... 300 h
 continuous 1:100 on relative scale

Time setting t:

Recovery time:

at DC 24 V: approx. 15 ms
 at DC 240 V: approx. 50 ms
 at AC 230 V: approx. 80 ms
Repeat accuracy: $\pm 0.5\%$ of selected
 end of scale value + 20 ms

Voltage and

temperature influence:

$\leq 1\%$ with the complete operating range

Input

Nominal voltage U_N :

AC/DC 12 ... 240 V

Voltage range:

0.8 ... 1.1 U_N

Frequency range (AC):

45 ... 400 Hz

Nominal consumption

at AC 12 V: approx. 1.5 VA
 at AC 24 V: approx. 2 VA
 at AC 240 V: approx. 3 VA
 at DC 12 V: approx. 1 W
 at DC 24 V: approx. 1 W
 at DC 240 V: approx. 1 W

Release voltage (A1/A2)

AC 50 Hz: Delayed contact Instantaneous contact
 approx. 7.5 V approx. 3 V
 DC: approx. 7 V approx. 3.3 V

Max. permitted residual current with 2-wire proximity sensor control (A1/A2)

up to AC/DC 150 V: AC resp. DC 5 mA
 up to AC/DC 264 V: AC resp. DC 3 mA

Control voltage (B1/A2)

MK 9906N.82/500: AC/DC 12 ... 240 V

Voltage range (B1/A2):

0.8 ... 1.1 U_N

Control current (B1)

MK 9906N.82/500: approx. 1 mA, over complete voltage range

Release voltage (B1/A2)

MK 9906N.82/500
 AC 50 Hz: approx. 3.5 V
 DC: approx. 3 V

Output

Contacts

MK 9906N.82: 2 changeover contacts, one programmable as instantaneous

contact:

without bridge X1-X2: 25-26-28 delayed changeover contact
 with bridge X1-X2: 21-22-24 instantaneous contact at U_N on A1-A2
 2 x 4 A

Thermal current I_{th} :

Switching capacity

to AC 15
 NO contact: 3 A / AC 230 V IEC/EN 60 947-5-1
 NC contact: 1 A / AC 230 V IEC/EN 60 947-5-1
 to DC 13:
 1 A / DC 24 V

Electrical life

to AC 15 at 1 A, AC 230 V: 1.5 x 10⁵ switching cycles IEC/EN 60 947-5-1

Permissible switching frequency:

36 000 switching cycles / h

Short circuit strength

max. fuse rating:

4 A gL IEC/EN 60 947-5-1

Mechanical life:

$\geq 30 \times 10^6$ switching cycles

Technical Data

General Data

Operating mode:	Continuous operation	
Temperature range:	- 20 ... + 60°C	
Clearance and creepage distances		
rated impulse voltage / pollution degree:	4 kV / 2	IEC 60 664-1
EMC		
Electrostatic discharge:	8 kV (air)	IEC/EN 61 000-4-2
Fast transients:	2 kV	IEC/EN 61 000-4-4
Surge voltages between wires for power supply:	1 kV	IEC/EN 61 000-4-5
HF-wire guided:	10 V	IEC/EN 61 000-4-6
Degree of protection		
Housing:	IP 40	IEC/EN 60 529
Terminals:	IP 20	IEC/EN 60 529
Housing:	Thermoplastic with V0 behaviour according to UL subject 94	
Vibration resistance:	Amplitude 0.35 mm, frequency 10 ... 55 Hz, IEC/EN 60 068-2-6 20 / 060 / 04 IEC/EN 60 068-1 EN 50 005	
Climate resistance:		
Terminal designation:	DIN 46 228-1/-2/-3/-4	
Wire connection		
Screw terminals (integrated):	1 x 4 mm ² solid or 1 x 2.5 mm ² stranded ferruled or 2 x 1.5 mm ² stranded ferruled or 2 x 2.5 mm ² solid	
Insulation of wires or sleeve length:	8 mm	
Plug in with screw terminals		
max. cross section for connection:	1 x 2.5 mm ² solid or 1 x 2.5 mm ² stranded ferruled	
Insulation of wires or sleeve length:	8 mm	
Plug in with cage clamp terminals		
max. cross section for connection:	1 x 4 mm ² solid or 1 x 2.5 mm ² stranded ferruled	
min. cross section for connection:	0.5 mm ²	
Insulation of wires or sleeve length:	12 ±0.5 mm	
Wire fixing:	Plus-minus terminal screws M 3.5 box terminals with wire protection or cage clamp terminals	
Mounting:	DIN rail	IEC/EN 60 715
Weight:	150 g	

Dimensions

Width x height x depth

MK 9906N:	22.5 x 90 x 97 mm
MK 9906N PC:	22.5 x 111 x 97 mm
MK 9906N PS:	22.5 x 104 x 97 mm

UL-Data

Switching capacity:

Ambient temperature 60°C: Pilot duty B300
5A 250Vac G. P.

Wire connection:

60°C / 75°C copper conductors only
Screw terminals fixed: AWG 20 - 12 Sol/Str Torque 0.8 Nm
Plug in screw: AWG 20 - 14 Sol Torque 0.8 Nm
AWG 20 - 16 Str Torque 0.8 Nm

Plug in cage clamp: AWG 20 - 12 Sol/Str



Technical data that is not stated in the UL-Data, can be found in the technical data section.

Standard Type

MK 9906N.82/61	AC/DC 12 ... 240 V	0.05 s ... 300 h
Article number:	0057517	
• Output:	2 changeover contacts, one programmable as instantaneous contact	
• Nominal voltage U_N :	AC/DC 12 ... 240 V	
• Time ranges:	0.05 s ... 300 h	
• Width:	22.5 mm	

Variants

MK 9906N.82:	without connection facility for a remote potentiometer.
MK 9906N.82/500:	with connection facility for a remote potentiometer 10 kΩ to adjust the time and additional control input B1 for time interruption / time addition.

Ordering example for variants

MK 9906N .82 / / /61 AC/DC 12 ... 240 V 0.05 s ... 300 h

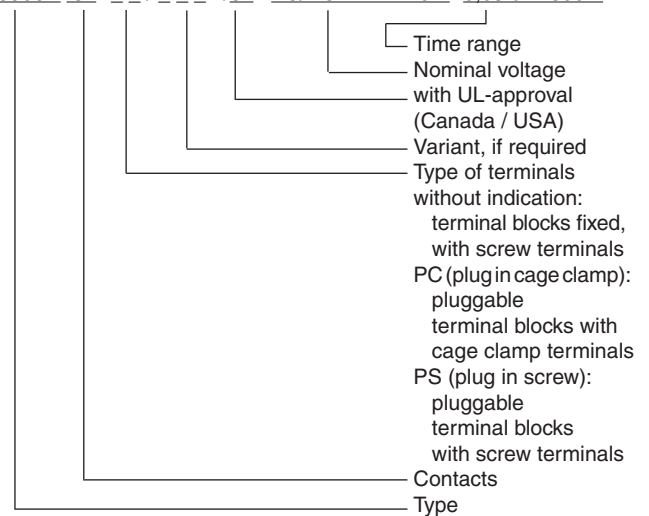

Options with Pluggable Terminal Blocks

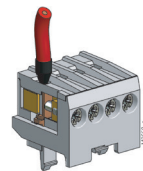

Screw terminal (PS/plugin screw)

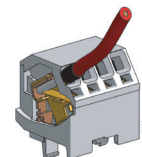

Cage clamp (PC/plugin cage clamp)

Notes

Removing the terminal blocks with cage clamp terminals

1. The unit has to be disconnected.
2. Insert a screwdriver in the side recess of the front plate.
3. Turn the screwdriver to the right and left.
4. Please note that the terminal blocks have to be mounted on the belonging plug in terminations.

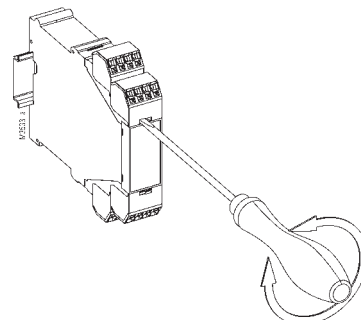

Accessories

AD 3:

External potentiometer 10 kΩ
Article number: 0028962

The external potentiometer is used for remote setting of the time delay. The internal potentiometer of the timer must be set to min. time delay.

Degree of protection
front side:

IP 60

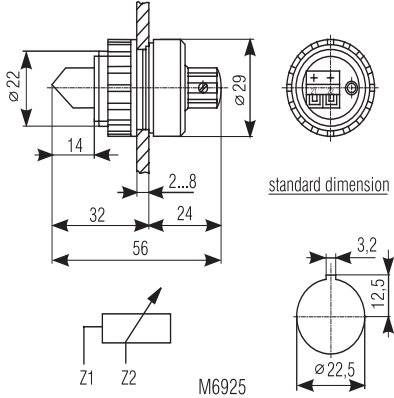

Connection Examples

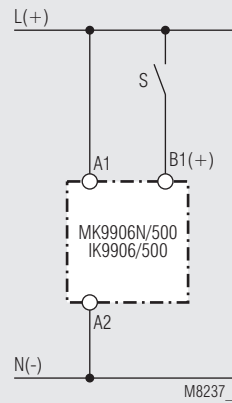
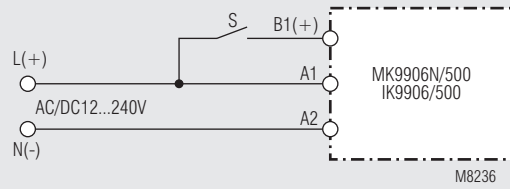

Control with parallel connected load

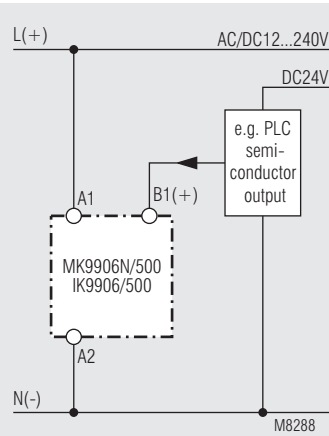

Connection with 2 different control voltages